

PRODUCT INFORMATION PACKET

Model No: 256TTFCA6092

Catalog No: GT3220

10 HP Close-Coupled Pump Motor, 3 phase, 1200 RPM, 575 V, 256JMV Frame, TEFC
JM Motors



Nameplate Specifications

Output HP	10 Hp	Output KW	7.5 kW
Frequency	60 Hz	Voltage	575 V
Current	11.2 A	Speed	1180 rpm
Service Factor	1.15	Phase	3
Efficiency	91 %	Power Factor	74
Duty	Continuous	Insulation Class	F
Design Code	B	KVA Code	G
Frame	256JMV	Enclosure	Totally Enclosed Fan Cooled
Thermal Protection	No	Ambient Temperature	40 °C
Drive End Bearing Size	6309	Opp Drive End Bearing Size	6209
UL	Recognized	CSA	Y
CE	Y	IP Code	43

Technical Specifications

Electrical Type	Squirrel Cage Inverter Rated	Starting Method	Line Or Inverter
Poles	6	Rotation	Reversible
Resistance Main	.935 Ohms	Mounting	Rigid Base
Motor Orientation	Horizontal Or Shaft Down	Drive End Bearing	Ball
Opp Drive End Bearing	Ball	Frame Material	Cast Iron
Shaft Type	JM	Overall Length	27.80 in
Shaft Diameter	1.250 in	Shaft Extension	5.25 in
Assembly/Box Mounting	F1/F2 CAPABLE		
Outline Drawing	SS620564-256	Connection Drawing	EE7300

This is an uncontrolled document once printed or downloaded and is subject to change without notice. Date Created:03/11/2020

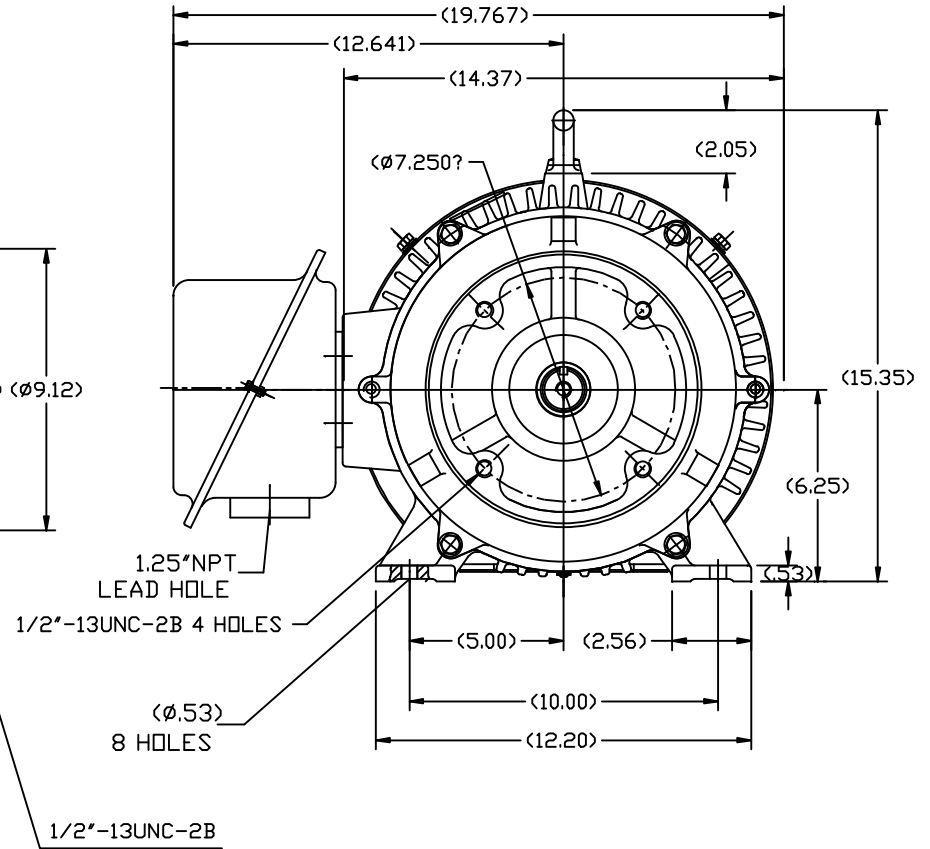
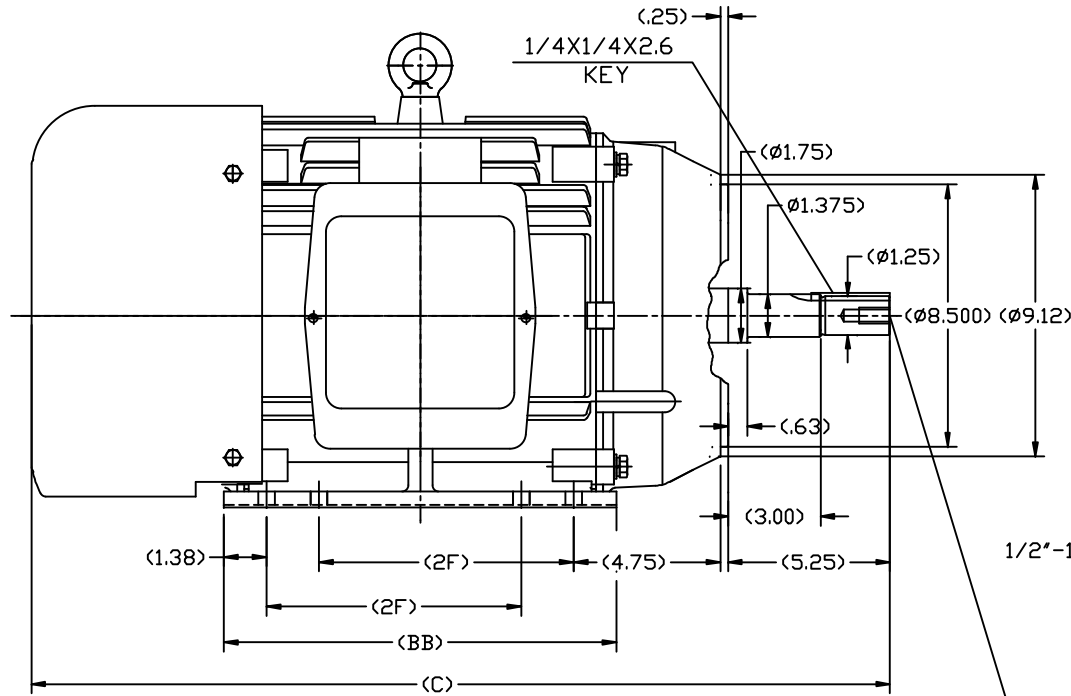

254	26.60	12.80	8.25
256	27.80	13.98	10.00
FRAME	C	BB	2F

		TOLERANCES UNLESS SPECIFIED		REGAL-BELOIT CORPORATION		DRAWN LSJ 05-16-2012			
		DEC.	INCHES			CHK			
		.X	±.1	TITLE OUTLINE 254/256TC FR-TEFC-CAST IRON		APPD			
		.XX	±.03			SCALE 1=4			
		.XXX	±.005			REF			
		.XXXX	±.0005	MAT'L.	FMF	HWADA			
NO.	REVISION	BY & DATE	CHK	ANG	±1/2	FINISH	PREV		
THIS DRAWING IN DESIGN AND DETAIL IS OUR PROPERTY AND MUST NOT BE USED EXCEPT IN CONNECTION WITH OUR WORK. ALL RIGHTS OF DESIGN AND INVENTION ARE RESERVED. THIS IS AN ELECTRONICALLY GENERATED DOCUMENT - DO NOT SCALE THIS PRINT				RFP	CAD FILE	SS620564	SIZE	DRAWING NO.	REV.
				DIST			B	SS620564	

**THREE PHASE - SINGLE VOLTAGE
MOTOR - CONDUIT BOX @ 'A'**

**TO REVERSE ROTATION:
INTERCHANGE ANY TWO
LINE LEAD CONNECTIONS.**

TERMINAL BLOCK WHEN SPECIFIED



VIEW OF TERMINAL END

**IF MOTOR HAS
6 LEADS**



A-9806 DECAL

**OPTIONAL CORD
CONNECTION**

- L1 WHITE
- L2 RED
- L3 BLACK

DRAWING REVISION AB	REVISION BY JJB	DATE 06-27-2017
ECO ECO-0125361	APPROVED BY TB	DATE 06-27-2017
ECO DESCRIPTION UPDATED TO CURRENT STANDARDS		
<small>COPYRIGHT REGAL BELOIT AMERICA, INC. ALL RIGHTS RESERVED. PROPRIETARY AND CONFIDENTIAL INFORMATION - THIS DOCUMENT IS THE PROPERTY OF REGAL BELOIT AMERICA, INC. ("OWNER") AND CONTAINS OWNER'S PROPRIETARY INFORMATION. ANY PERSON, CORPORATION OR OTHER FIRM RECEIVING IT IS DEEMED, BY RECEIVING IT, TO AGREE THAT IT, AND/OR ANY PART OF IT, SHALL NOT BE DISCLOSED TO ANY PERSON, CORPORATION OR OTHER ENTITY, DUPLICATED, AND/OR USED, EXCEPT AS EXPRESSLY APPROVED IN WRITING IN ADVANCE BY OWNER. THIS DOCUMENT SHALL BE RETURNED TO OWNER UPON REQUEST. IT MAY BE SUBJECT TO CERTAIN RESTRICTIONS UNDER APPLICABLE EXPORT CONTROL LAWS AND REGULATIONS.</small>		



DRAWN BY DA
DATE 03-26-1993
APPROVED BY TB
DATE 03-26-1993
REFERENCE
THIRD ANGLE PROJECTION

Regal Beloit America, Inc.		
		DESCRIPTION CONNECTION DIAGRAM EXTERNAL - SINGLE VOLTAGE - 3Ø MOTOR
MATERIAL	PROCESS/FINISH	
SIZE A	DRAWING NUMBER EE7300	SHEET 1 OF 1

